

MOTOMAN GP25, GP25-12

Handling & General Applications
with the GP-series



The MOTOMAN GP25 is a fast and precise 6-axis industrial robot with a payload capacity of up to 25 kg. With a reach of 1730 mm and a high repeatability of ± 0.06 mm, it is ideally suited to assembly tasks, but also universal handling tasks, CNC machine tool tending or packaging. With its payload capacity of 12 kg, the MOTOMAN GP25-12 offers an even larger working range of 2010 mm with a repeatability of ± 0.08 mm. The streamlined modern industrial design minimizes the space requirements at the installation site.

Cable entry from the side at the pedestal enables space-saving and uncluttered integration into the environment, irrespective of the intended installation position. The prepared routing of the supply lines in the arm enables optimal integration of the grippers or sensor systems, often dispensing with the need for an external media package. This reduces also interference contours.

A world of possibilities is open to the MOTOMAN GP25/GP25-12 robots with the numerous functions of the MOTOMAN YRC1000 controller. In conjunction with the conventional teach pendant, these robots are reliable mechanical engineering partners. With the innovative operator control concept of the SmartPendant, it provides an excellent point of entry into industrial automation.

As standard, the MOTOMAN GP25 and GP25-12 are designed with the high protection classification IP67 (wrist). Other variants of the MOTOMAN GP25 (e.g. with food-compatible grease in the food industry, special anti-corrosion coating for applications in aggressive ambient conditions, or as a cleanroom version) are optionally available.

KEY BENEFITS

- Flexible, fast and powerful
- Large working range: 1730 and 2010 mm
- Reduced interference contours due to optimized design
- Simple commissioning and maintenance

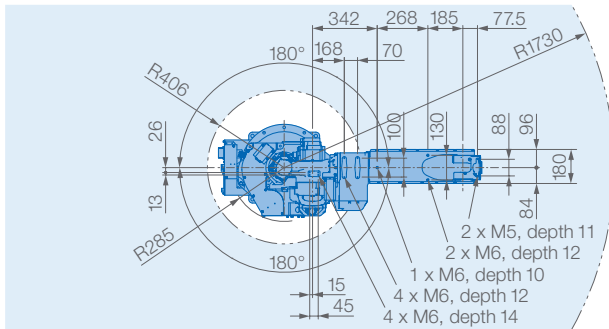
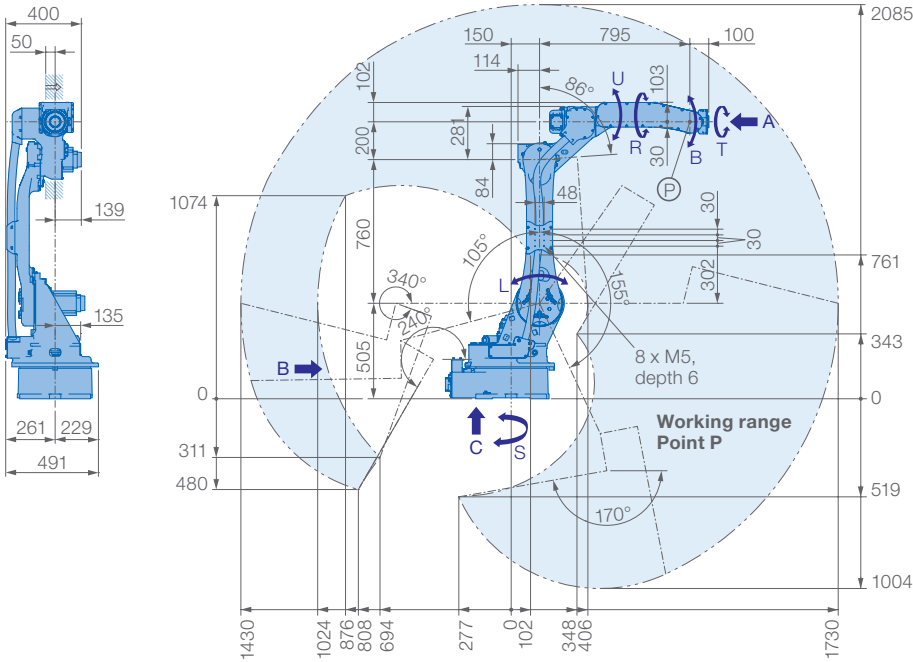

View A

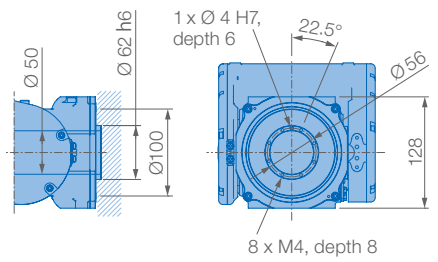

View B

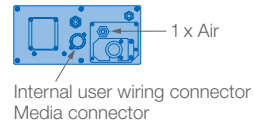

View C

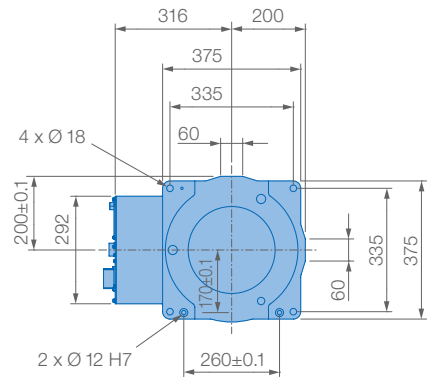

Prevent interaction of the robot with:

- Corrosive gases, liquids or explosive gases
- Exposure to water, oil or dust
- Excessive electrical noise (plasma)

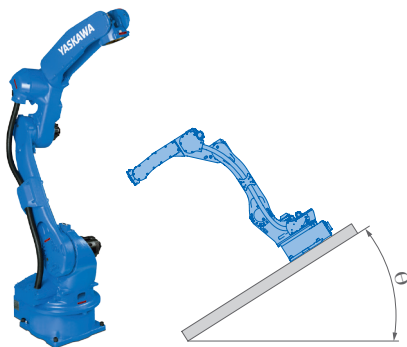

Allowable wrist load

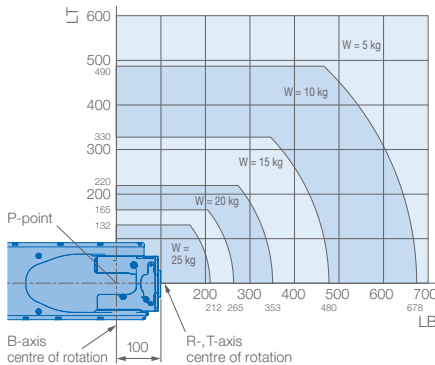

Mounting options: Floor, ceiling, wall, tilt*

Protection class version YR-1-25VXH25-A00
Standard: Main axes (S, L, U) IP54, wrist IP67

Protection class version YR-1-25VXH25-C00:
Main axes (S, L, U) IP65, wrist IP67

* tilt with condition of angle – see table below

Robot installation angle θ [deg.]	S-axis operating range [deg.]
$0 \leq \theta \leq 30$	± 180 degrees or less (no limit)
$30 < \theta \leq 35$	± 60 degrees or less
$35 < \theta$	± 30 degrees or less

Specifications GP25					
Axes	Maximum motion range [°]	Maximum speed [°/sec.]	Allowable moment [Nm]	Allowable moment of inertia [kg · m ²]	Controlled axes
S	± 180	210	–	–	6
L	$+155/-105$	210	–	–	Max. payload [kg]
U	$+160/-86$	265	–	–	Repeatability [mm]
R	± 200	420	52	2.3	Max. working range R [mm]
B	± 150	420	52	2.3	Temperature [°C]
T	± 455	885	32	1.2	Humidity [%]
					Weight [kg]
					Power supply, average [KVA]

* Conforms to ISO 9283 ** Varies in accordance with applications and motion patterns Note: SI units are used for specifications.

All dimensions in mm

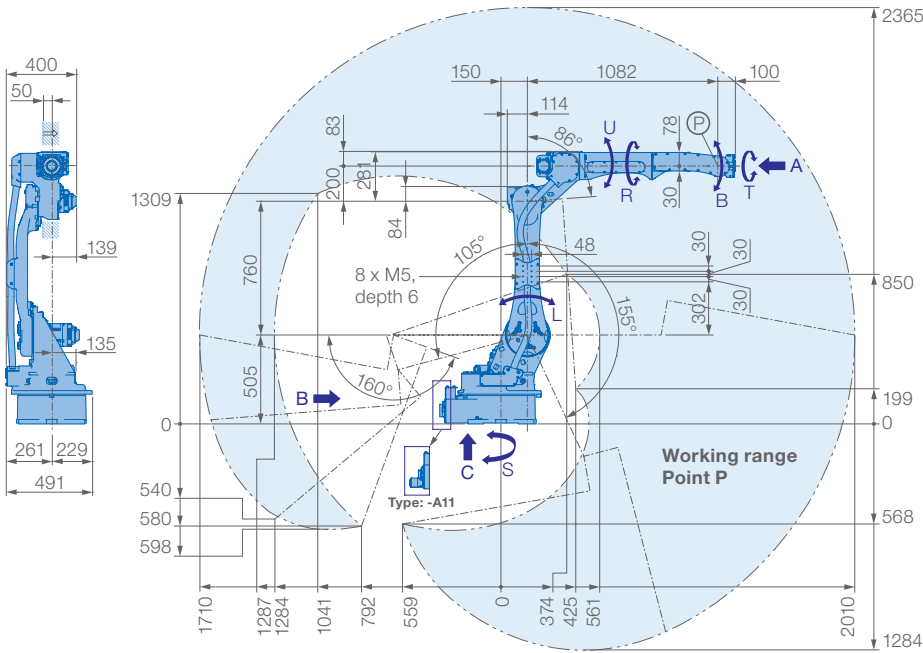

View A

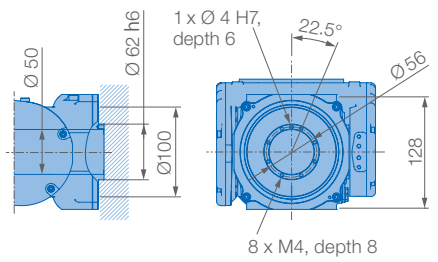

View B

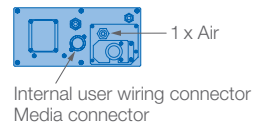

View C

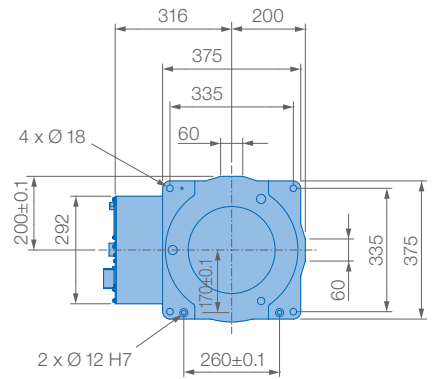

Prevent interaction of the robot with:

- Corrosive gases, liquids or explosive gases
- Exposure to water, oil or dust
- Excessive electrical noise (plasma)



Allowable wrist load

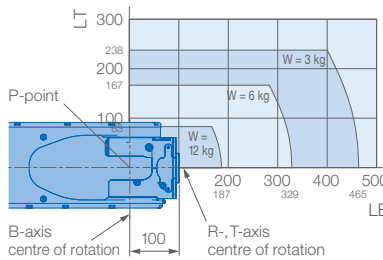

Mounting options: Floor, ceiling, wall, tilt*

Protection class: Main axes (S, L, U) IP54 (option 65), wrist IP67

* tilt with condition of angle – see table below

Robot installation angle θ [deg.]	S-axis operating range [deg.]
$0 \leq \theta \leq 30$	± 180 degrees or less (no limit)
$30 < \theta \leq 35$	± 60 degrees or less
$35 < \theta$	± 30 degrees or less

Specifications GP25-12

Axes	Maximum motion range [°]	Maximum speed [°/sec.]	Allowable moment [Nm]	Allowable moment of inertia [kg · m ²]	Controlled axes	6
S	± 180	210	–	–	Max. payload (on U-axis) [kg]	12 (9)
L	$+155/-105$	210	–	–	Repeatability [mm]	$\pm 0.08^*$
U	$+160/-86$	220	–	–	Max. working range R [mm]	2010
R	± 200	435	22	0.65	Temperature [°C]	0 to +45
B	± 150	435	22	0.65	Humidity [%]	20 – 80
T	± 455	700	9.8	0.17	Weight [kg]	260
					Power supply, average [KVA]	2.0**

* Conforms to ISO 9283 ** Varies in accordance with applications and motion patterns Note: SI units are used for specifications.

All dimensions in mm

YASKAWA GROUP

AT	Yaskawa Austria Schwechat/Wien +43(0)1-707-9324-15
CZ	Yaskawa Czech s.r.o. Rudná u Prahy +420-257-941-718
ES	Yaskawa Ibérica, S.L. Gavà/Barcelona +34-93-6303478
FR	Yaskawa France SARL Le Bignon +33-2-40131919
FI	Yaskawa Finland Oy Turku +358-(0)-403000600
GB	Yaskawa UK Ltd. Banbury +44-1295-272755
IT	Yaskawa Italia s.r.l. Torino +39-011-9005833
IL	Yaskawa Europe Technology Ltd. Rosh Ha'ayin +972-3-9004114
NL	Yaskawa Benelux B.V. Eindhoven +31-40-2895500
PL	Yaskawa Polska Sp. z o.o. Wrocław +48-71-7928670
RU	Yaskawa Europe Holding AB Moskva +46-480-417-800
SE	Yaskawa Nordic AB Torsås +46-480-417-800
SI	Yaskawa Slovenia Ribnica +386-1-8372-410
TR	Yaskawa Turkey Elektrik Ticaret Ltd. Sti. İstanbul +90-216-5273450
ZA	Yaskawa Southern Africa (PTY) Ltd Johannesburg +27-11-6083182

DISTRIBUTORS

BG	ARAMET ROBOTICS Ltd. Yambol +359-885 317 294 Kammarton Bulgaria Ltd. Sofia +359-02-926-6060
DK	Robotcenter Danmark Løsning +45 7022 2477
EE	RKR Seadmed OÜ Tallinn/Estonia +372-68-35-235
GR	Gizelis Robotics Schimatari Viotias +30-2262057199
HU	Flexman Robotics Kft Budapest +36 1 259 0981
LT	Profibus UAB Panevezys +370-45-518575
NO	Skala Robotech AS Lierstranda +47-32240600
PT	ROBOPLAN Lda Aveiro +351-234 943 900
RO	Sam Robotics srl Timisoara +40 720 279 866 MPL Automation S.R.L. Satu Mare +40 261 750 741 NORMANDIA S.R.L. Braşov +40 268 549 236



Yaskawa Headquarters

Yaskawa Europe GmbH
Robotics Division
Yaskawastraße 1
85391 Allershausen, Germany
Tel. +49 (0) 8166/90-0
Fax +49 (0) 8166/90-103

robotics@yaskawa.eu.com
www.yaskawa.eu.com

Yaskawa Academy and sales office Frankfurt

Yaskawa Europe GmbH
Robotics Division
Hauptstraße 185
65760 Eschborn, Germany
Tel. +49 (0) 6196/77725-0
Fax +49 (0) 6196/77725-39

All drawing dimensions in mm.
Technical data may be subject to change without previous notice.
Please request detailed drawings at robotics@yaskawa.eu.com.

YR-1-25VXH25-A00, YR-1-25VXH25-C00
YR-1-25VXH25-12-A00
B-07-2020, A-No. 206026

YASKAWA